

FITTING INSTRUCTION

Clamp mark in acc. with		Cables joining
ISO	PN	
1	L	Left directional lights
2	+	Rear fog lights
3	31	Ground
4	R	Right directional lights
5	58R	Right side parking lights
6	54	Stoplights
7	58L	Left side parking lights

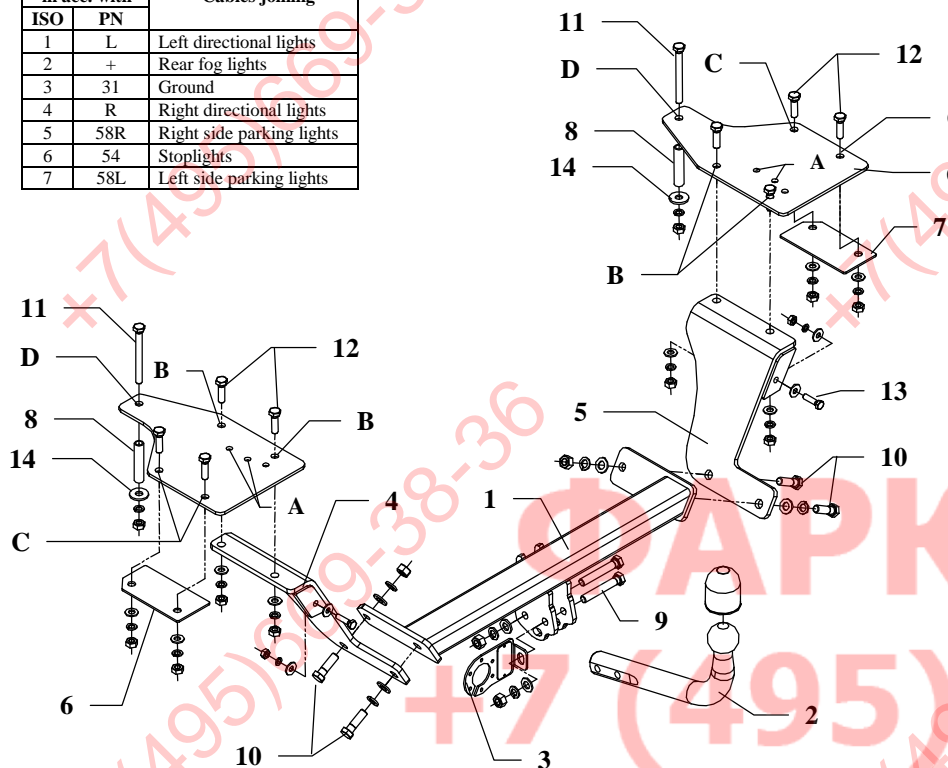

This towing hitch is designed to assembly in following cars: **SUZUKI SX4, 2 WD** and **FIAT SEDICI, 2WD**, both produced since 2006, catalogue number **W25** and is prepared to tow trailers max total weight **1200 kg** and max vertical load **50 kg**.

From manufacturer

Thank you for buying our product. Their reliability has been confirmed in many tests. Reliability of towing hitch depends also on correct assembly and right operation. For this reasons we kindly ask to read carefully this instruction and apply to hints.

The towing hitch should be install in points described by a car producer.

The instruction of the assembly

1. Disassemble a rear bumper and rear light unit.
2. Clean out a trunk, take out a floor finish and disassemble plastic cover elements from side and rear walls.
3. To a trunk put fish-plates (pos. 6) in this way so holes (pos. A) agree with original threaded hole M6. Fix fish-plates to trunk floor.
4. Through holes (pos. B, C and D) drill port holes using bit $\varnothing 10,5\text{mm}$.
5. Disassemble fish-plates and enlarge holes (pos. D) by bit $\varnothing 15\text{mm}$. Note! Enlarge only in one face - from inside.
6. To enlarged holes put distance sleeves (pos. 8).
7. Reassemble fish-plates (pos. 6) again. Note! Between fish-plate (pos. 6) and trunk floor put cut fish-plate (pos. 7) as shown in the drawing. To holes in fish-plates put bolts as shown in the drawing.
8. Underneath the car, on protruding bolts M10x35mm (pos. 12) fix loosely side brackets (pos. 4 and 5).
9. Between mounted side brackets (pos. 4 and 5) put main bar of the towing hitch (pos. 1) and fix using bolts M12x40mm (pos. 10).
10. Fix tow-ball (pos. 2) with socket plate (pos. 3) using bolts M12x75mm (pos. 9) from accessories.
11. Reassemble a bumper after cut out its interferer fragment in lower part as necessary.
12. Tighten all bolts according to the torque shown in the table.
13. Connect electric wires of 7-poles socket according to the instruction of the car. (Recommend to make at authorized service station).
14. Complete paint layer damaged during installation.

Torque settings for nuts and bolts (8,8):	
M 8 - 25 Nm	M 10 - 55 Nm
M 12 - 85 Nm	M 14 - 135 Nm









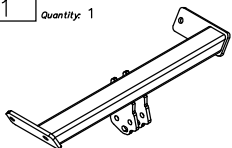

NOTE

After install the towing hitch you should get adequate note in registration book (at authorised service station).The car should be equipped with:

- Indicators
- Tow mirrors

After 1000km check all bolts. The ball of towing hitch must be always kept clear and conserve with a grease.

Towing hitch accessories:

Pos. 1 Name: Main bar Quantity: 1	Pos. 6 Name: Fish-plate Quantity: 2	Pos. 12 Name: Bolt 8,8 B Quantity: 8 Dim.: M10x35mm	Pos. 18 Name: Nut 8 B Quantity: 2 Dim.: M8
	Pos. 7 Name: Truncate fish-plate Quantity: 2	Pos. 13 Name: Bolt 8,8 B Quantity: 2 Dim.: M8x30mm	Pos. 19 Name: Plain washer Quantity: 6 Dim.: Ø 13 mm
Pos. 2 Name: Tow ball Quantity: 1	Pos. 8 Name: Distance sleeve Quantity: 2 Dim.: Ø15xØ11mm L=70mm	Pos. 14 Name: Washer Quantity: 2 Dim.: Ø30xØ12x3mm	Pos. 20 Name: Plain washer Quantity: 8 Dim.: Ø 10,5 mm
	Pos. 9 Name: Bolt 8,8 B Quantity: 2 Dim.: M12x75mm	Pos. 15 Name: Washer Quantity: 4 Dim.: Ø22xØ9x2mm	Pos. 21 Name: Spring washer Quantity: 6 Dim.: Ø 12,2 mm
Pos. 3 Name: Socket plate Quantity: 1	Pos. 10 Name: Bolt 8,8 B Quantity: 4 Dim.: M12x40mm	Pos. 16 Name: Nut 8 B Quantity: 4 Dim.: M12	Pos. 22 Name: Spring washer Quantity: 10 Dim.: Ø 10,2 mm
	Pos. 11 Name: Bolt 8,8 B Quantity: 2 Dim.: M10x100mm	Pos. 17 Name: Nut 8 B Quantity: 10 Dim.: M10	Pos. 23 Name: Spring washer Quantity: 2 Dim.: Ø 8,2 mm
Pos. 4 Name: Left bracket Quantity: 1			
Pos. 5 Name: Right bracket Quantity: 1			
		Pos. 24 Name: Ball cover Quantity: 1	



PPUH AUTO-HAK S.J.

Produkcja Haków Holowniczych
Henryk & Zbigniew Nejman
76-200 SŁUPSK ul. Stoneczna 16K
tel/fax (059) 8-414-414; 8-414-413
E-mail: office@autohak.com.pl
www.autohak.com.pl

Towing hitch (without electrical set)

Class: A50-X Cat. no. W25

Designed for:

SUZUKI SX4, 2 WD

and

FIAT SEDICI, 2WD

both produced since 2006

Technical data:

D-value: 7,1 kN

maximum trailer weight: **1200 kg**

maximum vertical cup load: **50 kg**

Approval number according to Directive 94/20/EC: **e20*94/20*0126*00**

Foreword

This towing hitch is designed according to rules of safety traffic regulations. The towing hitch is a safety component and can be install only by qualified personnel. Any alteration or conversion of the towing hitch is prohibited and would lead to cancellation of design certification. Remove insulating compound and underseal from vehicle (if present) in the area of the matting surfaces of the towing hitch. The vehicle manufacturer's specifications regarding trailer load and max. vertical cup load are decisive for driving whereat values for the towing hitch cannot be exceeded.

D-value formula:

$$\frac{\text{Max trailer weight [kg]} \times \text{Max vehicle weight [kg]}}{\text{Max trailer weight [kg]} + \text{Max vehicle weight [kg]}} \times \frac{9,81}{1000} = D \text{ [kN]}$$